

[Products](#)
[About Rane](#)
[Support](#)
[Reference](#)

# ML 1 Mic/Line Preamp

[Literature](#)
[Find a Dealer](#)

## General Description

The Rane ML 1 Mic / Line Preamp provides the answer when you just need a preamplified pair. Go from either dynamic, condenser or electret microphones to line-level with a minimum of noise, distortion, and hassle.

At the same time the ML 1 can convert those mics, or a stereo line source, to a digital output of your choice: AES3, S/PDIF coaxial or optical.

The ML 1's rear panel provides 48 V switchable Phantom Power with an indicator LED. Each channel has Mic / Line input selection with Gain trims between 18 dB and 66 dB. Input signal and Output Signal / Overload LEDs help set levels to other equipment whether you are looking at the front or the back panel. Inputs and outputs let you choose between balanced XLR or Euroblock connectors. The Euroblocks accept 22 to 12 guage wire.

The ML 1 utilizes one of the finest ultra low noise amplifier designs available. Featuring a true differential input with high common-mode rejection, use of the ML 1 guarantees performance usually found only in mixing consoles costing thousands of times as much.

A security cover for the rear panel Gain and Mic / Line switches is included for those set-and-forget installations. The internal power supply operates almost anywhere in the world with the proper IEC-C5 cord.

See the Data Sheet link below for complete specifications.

## Rear Panel

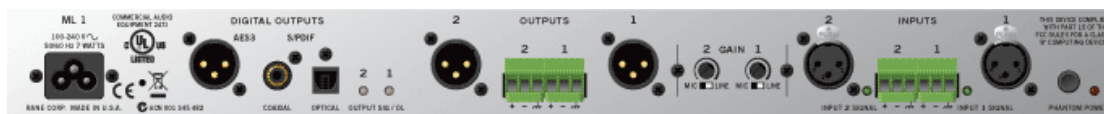

Click on the images for a close-up. Right-click to zoom and pan.

## Applications

Uses and applications for the ML 1 should be obvious. But here are some ideas to spark your imagination.

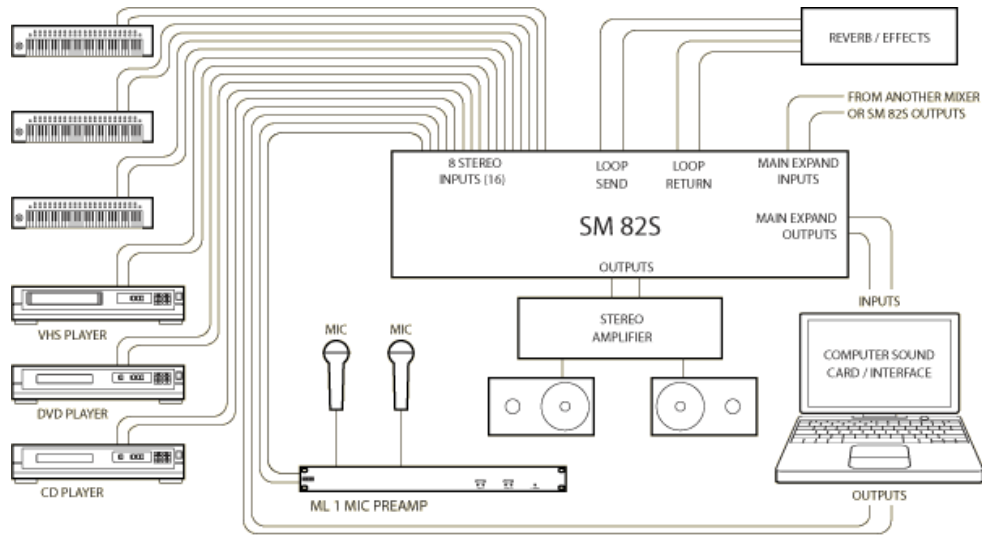

The ML 1 fills the need for adding a pair of microphone channels to line-level mixers, such as the [Rane SM 82S](#).

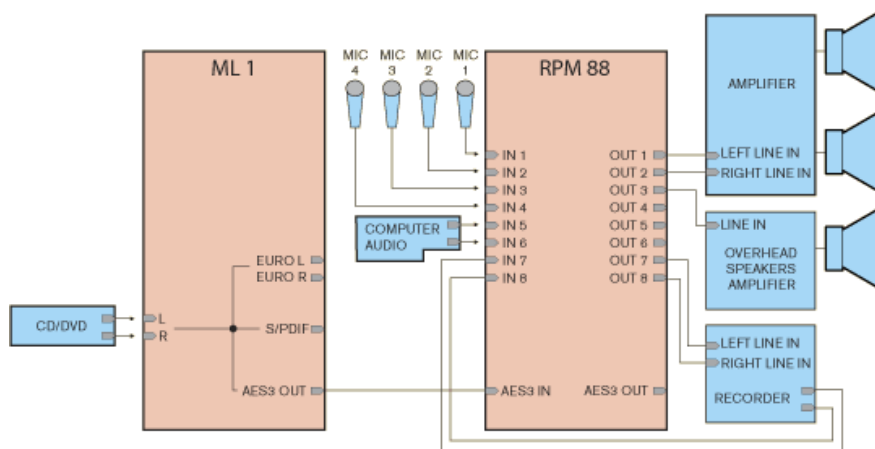

The versatility of the popular [Rane RPM 88](#) increases to 10 inputs using an ML 1 with a single cable: ML 1 digital out to RPM 88 digital in.

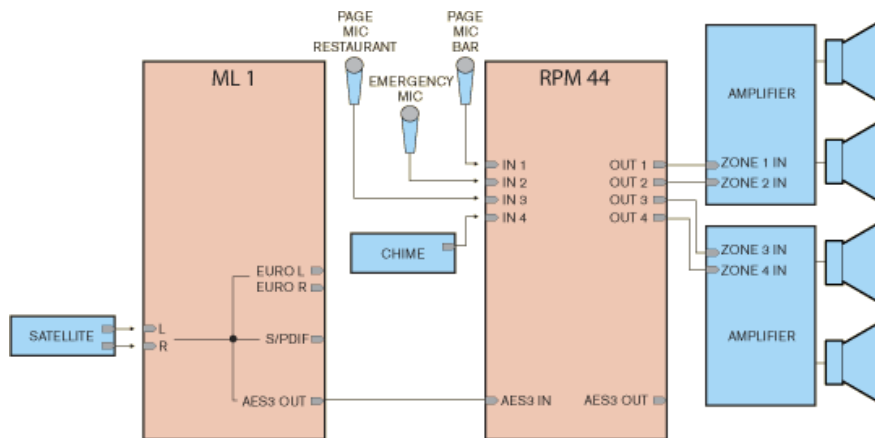

The [Rane RPM 44](#) increases to 6 inputs using an ML 1 with a single cable: ML 1 digital out to RPM 44 digital in.

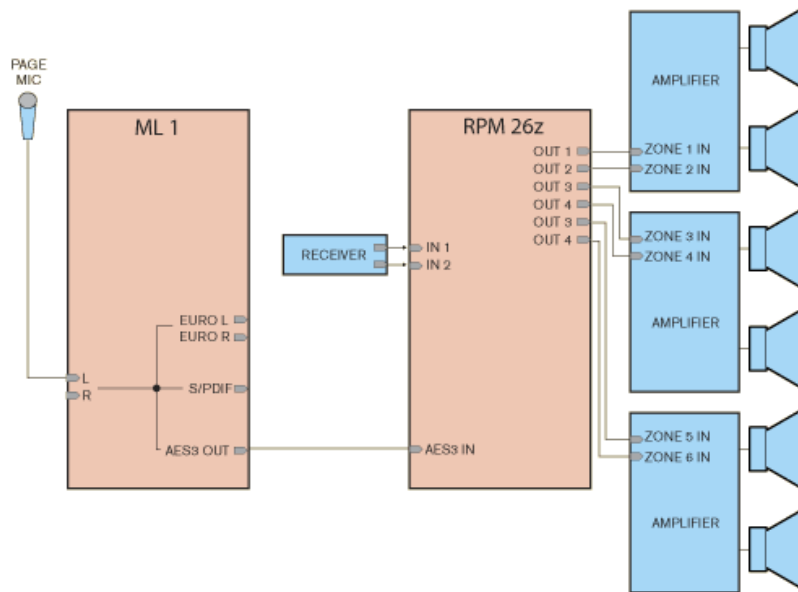

The [Rane RPM 26z](#) increases to 4 inputs using an ML 1 with a single cable: ML 1 digital out to RPM 26z digital in.

### Digital Recording

Another handy use for the ML 1 is in recording applications. Many popular products (including most computer sound cards) do not have a high enough quality mic preamp to suit the resolution of the digital processing electronics. Such irony. Using the ultra low noise ML 1 to bring the mic inputs up to extremely high quality line-level or digital signal is an easy and affordable solution for this dilemma. No garbage in; no garbage out.



### Microphone Types

The available gain and large input range of the ML 1 allows the use of virtually any type of microphone. True 48V phantom power guarantees the ML 1 works with every microphone. The better the mic, the better the ML 1 sounds.

### Alternative Products

- The [MS 1B](#) is a small and simple mic-in to line-out box with a volume control.
- The [NM 1](#) is a small mic preamp with Ethernet/Cobranet connectivity and a speaker output.
- The [CP 52](#), [CP 64S](#) and [DA 26](#) include mic preamps for paging applications.
- The [MLM 42](#), [MLM 82S](#), [MLM 103](#) are basic mic/line mixers.
- The [RPM 2m](#), [RPM 22](#), [RPM 44](#) and [RPM 88 Drag Net](#) products have mic level inputs, with no front panel controls, under software control, with all the signal processing you need.

### Product Literature

-  [Data Sheet \(100k\)](#)
-  [Manual \(100k\)](#)
-  [Schematic \(200k\)](#)

### Further Information

-  [RaneNote "Setting Sound System Level Controls"](#)
-  [ML 1 high res front panel JPG](#)

[Return to Top](#)

-  [ML 1 high res rear panel JPG](#)